

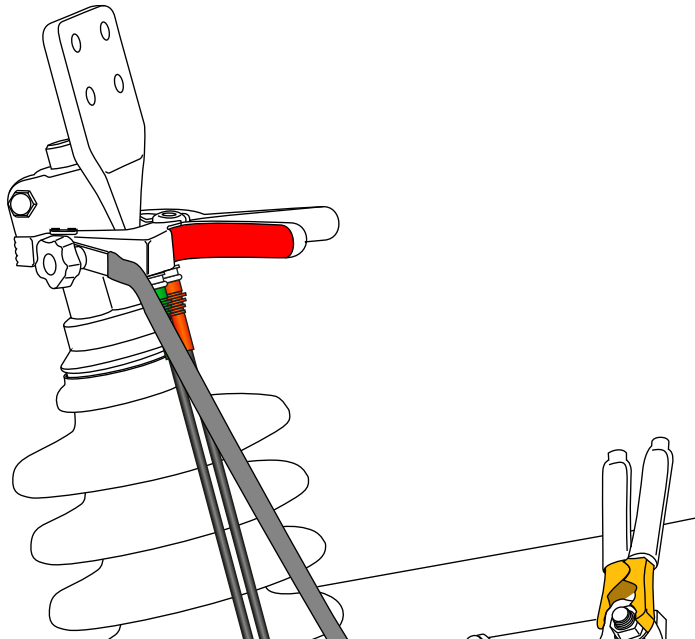

Newtons4th Ltd

SFRA45 QUICK MEASUREMENT GUIDE



1. Unwind Cable Reel to desired length and connect SFRA45+Interconnecting Cables+Cable Reel

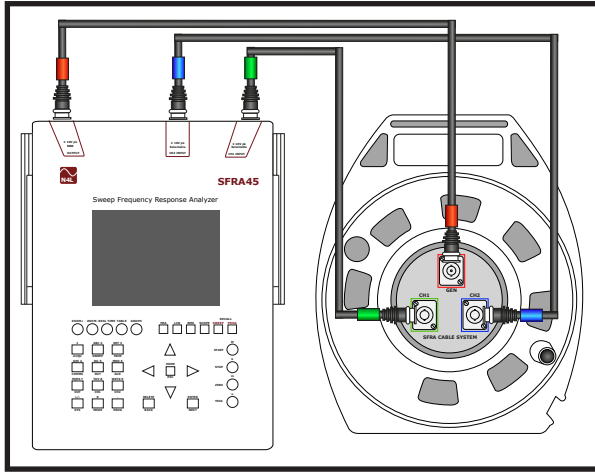

2. Connect GEN+CH1 BNC Cable Reel Connectors to First Clamp (Using F-Connector) and CH2 to Second Clamp

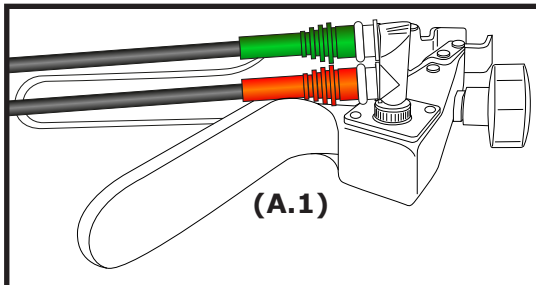

This clamp is referred to as Clamp A.1 on page 3 (step 5)

3. Connect 2x Earth Braids to Clamp Earth Points

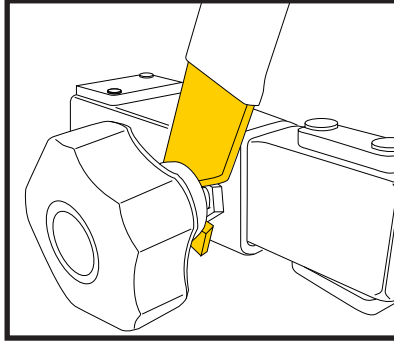

4. Power on SFRA45, note battery charge

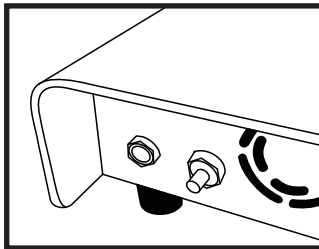

5. EXAMPLE A-B PHASE CONNECTIONS

Connect Clamp (A.1) to phase A Transformer Bushing, use braid clamps (B.1) to fasten Earth Braid (C.1) to the local earthing point

A PHASE

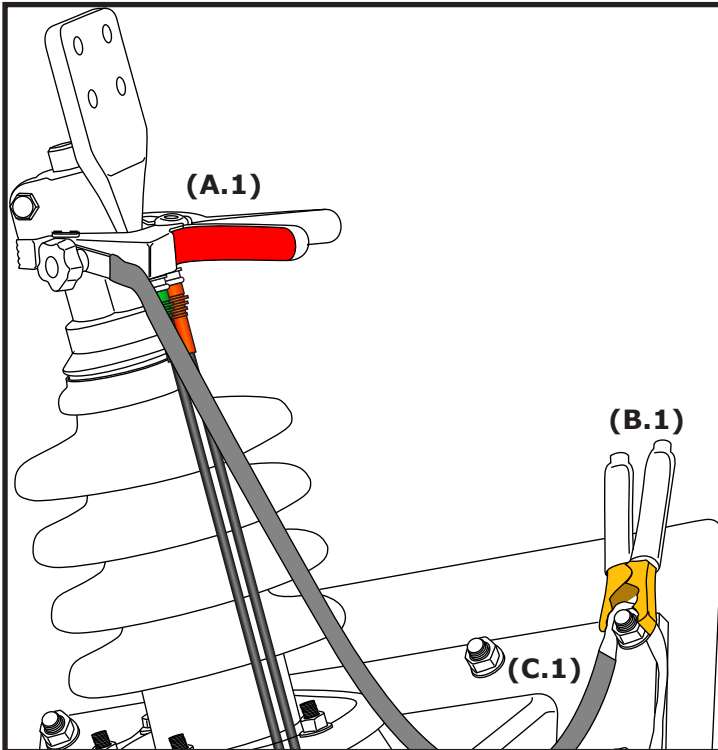

A.2, B.2 and C.2 are connected to phase B respectively

B PHASE

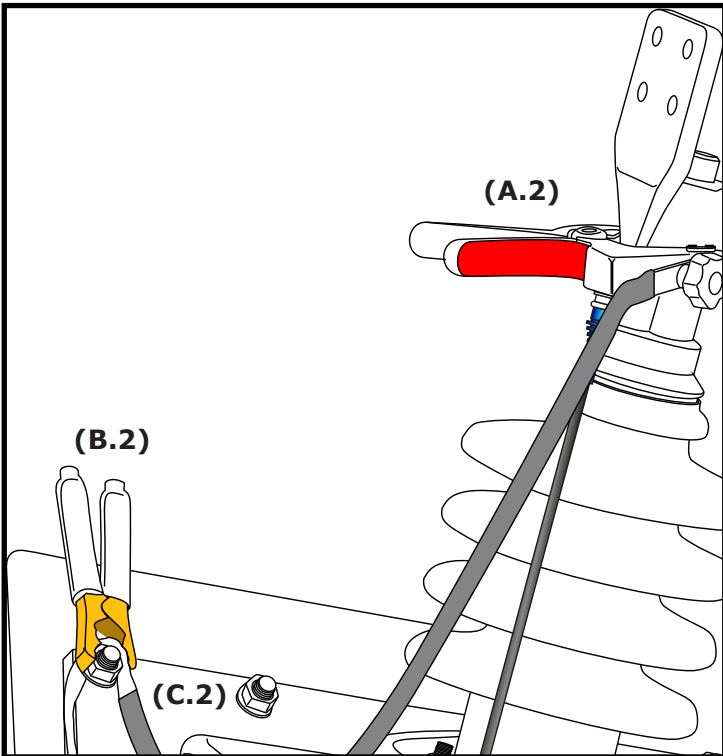

6. Enter "SWEEP" menu, check sweep settings

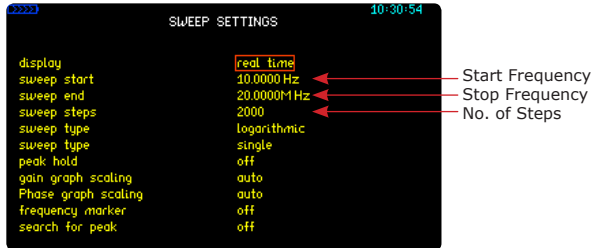

After changes are made, continue to press "HOME" until presented with the Main Display Screen

7. Set Output Voltage Level and Generator to "on"

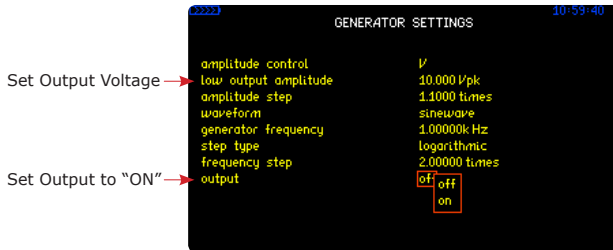

8. Set Instrument Measurement Speed in "ACQU MENU" to "Very Fast" initially, if results are noisy - reduce speed

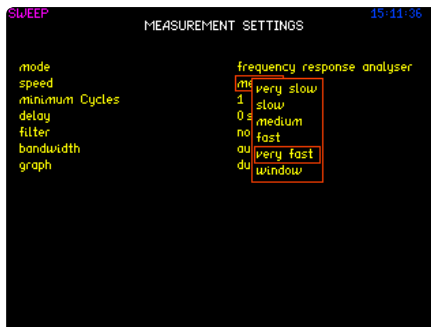

9. Ensure Both Clamps and Earth braids are connected to transformer (See Step 5) and press "START" on keypad

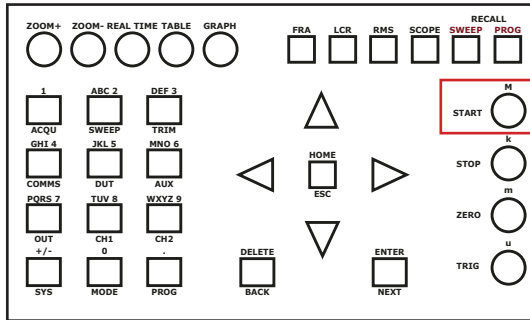

Wait for Sweep to complete, instrument will display "SWEEP" in top left of the display whilst the sweep is running.

9. During the sweep, use the "REAL TIME", "TABLE" and GRAPH" views as desired

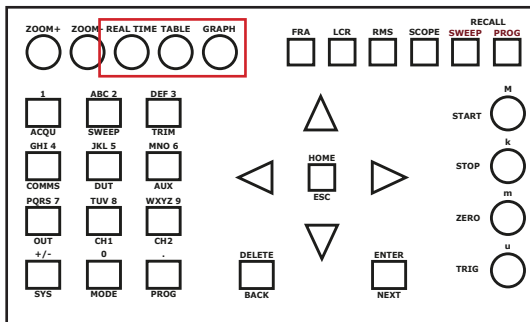

The results can be viewed in "Real Time" during a sweep, which is highly advantageous to detect poor wiring connections to the transformer.

10. Zoom In and Zoom Out of a graphical plot using the Zoom +/- buttons to analyse the results in more detail

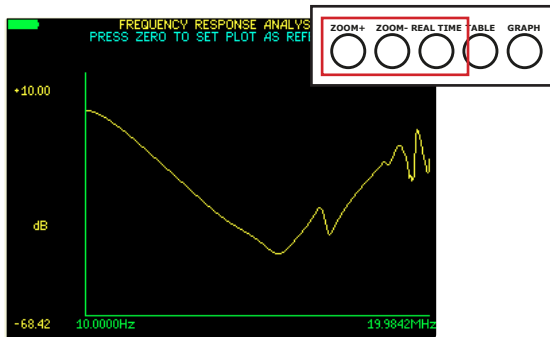

The Zoom function is also useful in the "Real Time Display" to enlarge certain sweep parameters during a sweep

11. To Save the sweep data, along with all transformer/ sweep details, enter the "DUT" menu and fill out as necessary

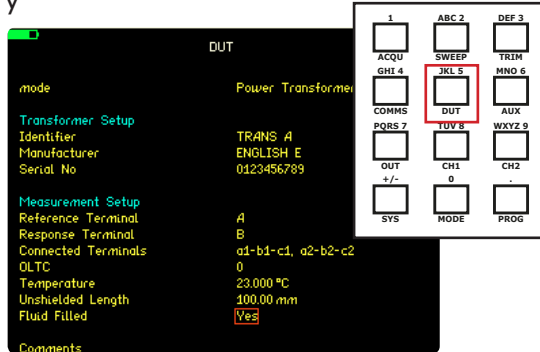

Once the transformer and sweep configuration details are set, press "ENTER" until presented with the standard measurement screen

12. Enter "PROG" Menu to save the sweep to memory, select the location and enter the name of the sweep

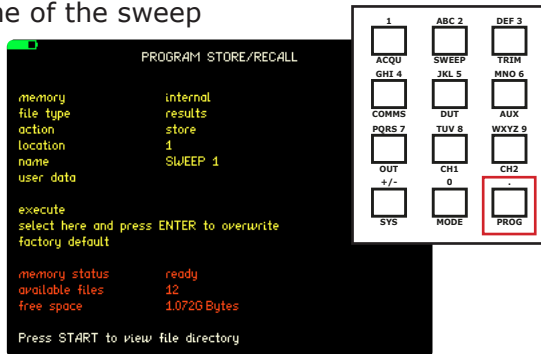

Select Internal/USB memory stick as required, take care not to overwrite other sweeps that are still needed. Move cursor to the "execute" menu option and select "ENTER" to store sweep

SETTING REFERENCE PLOTS

A major benefit of the SFRA45's standalone proprietary operating system is that the user can compare plots previously recorded. This can be performed in the field, real time without the requirement for a PC connection. It is advisable to use an existing plot as a "Reference Plot" whenever possible for a comparative measurement, this enables the engineer to detect a connection problem or genuine fault in the transformer at an early stage in the test.

1. Load Plot from memory : Existing plots can be stored in the instruments internal memory or on a memory stick. Recalling these plots is performed in the RECALL - SWEEP menu

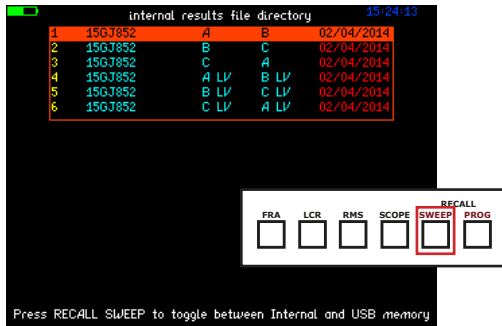

Selecting "ENTER" whilst highlighting the sweep to be recalled will load the sweep data along with all "DUT" and sweep settings

2. Setting the recalled plot as the "Reference Plot" for comparative measurements is performed by first selecting "GRAPH" to view the graphical representation of the plot and then the "ZERO" button

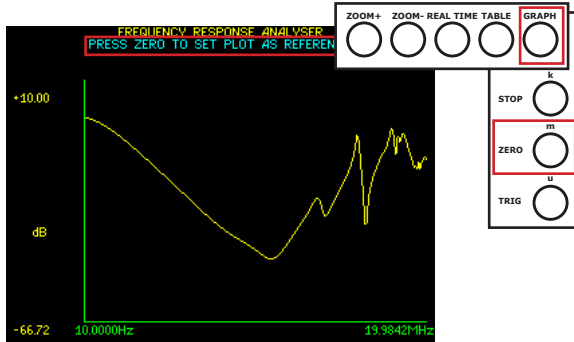

Guidance for setting the "Reference Plot" is given on the graphical display screen in light blue writing - "PRESS ZERO TO SET PLOT AS REFERENCE"

3. Once the "ZERO" button is pressed, the recalled plot changes to **Light Blue** in colour, this is now the reference plot

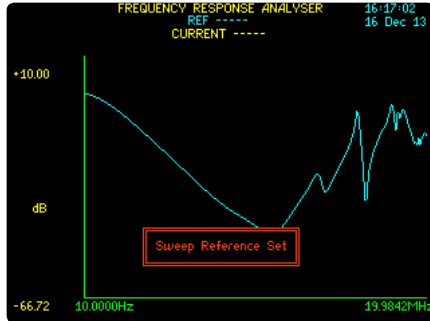

"Sweep Reference Set" will be displayed on screen once the Zero button is pressed

4. The previous sweep settings will already be loaded as a result of the "RECALL-SWEEP" function, therefore a new sweep can immediately commence with the "START" button

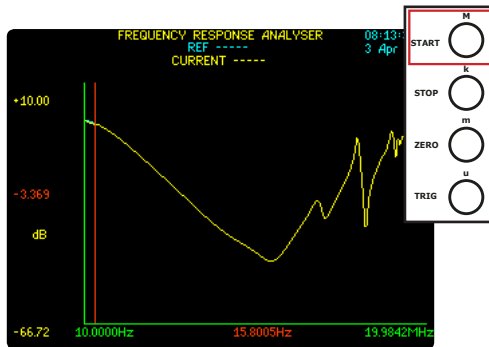

Once the new sweep has commenced, new sweep data will be displayed as a yellow line and the reference plot remains **light blue**

5. As the plot builds, it is possible to “ZOOM” in to the real time data and analyse the plot in more detail

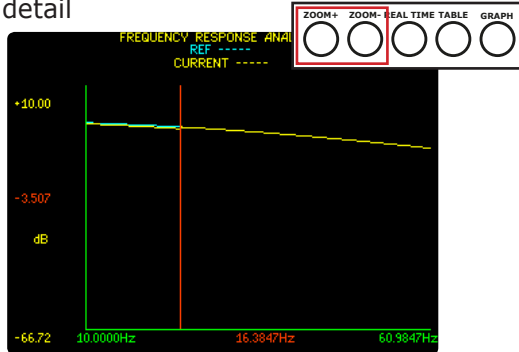

Zooming in will allow the engineer to quickly diagnose any connection/transformer issue

6. Once the sweep is complete, it is easy to compare the reference sweep and current sweep on the display without the need for a PC

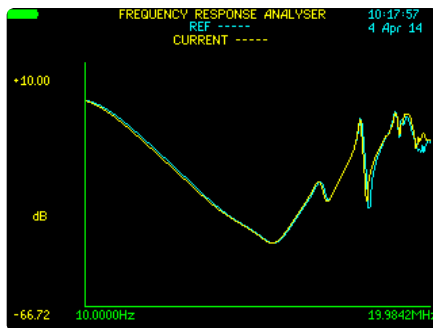

Once you are happy with the results, remember to save the data to the instrument internal memory or directly to the USB memory stick

TYPICAL TRANSFORMER TEST SEQUENCES AS PER IEC60076-18

Star Connected Winding with Tap Changer

Test No	CH1 (Clamp A.1, SIGNAL AND REFERENCE)	CH2 (Clamp A.2, RESPONSE)	Tap Position
1	Neutral	Line Terminal Phase 1	Max Turns
2	Neutral	Line Terminal Phase 2	Max Turns
3	Neutral	Line Terminal Phase 3	Max Turns
4	Neutral	Line Terminal Phase 1	Tap Winding Out of Circuit
5	Neutral	Line Terminal Phase 2	Tap Winding Out of Circuit
6	Neutral	Line Terminal Phase 3	Tap Winding Out of Circuit

Star Connected Winding without Tap Changer

Test No	CH1 (Clamp A.1, SIGNAL AND REFERENCE)	CH2 (Clamp A.2, RESPONSE)
1	Neutral	Line Terminal Phase 1
2	Neutral	Line Terminal Phase 2
3	Neutral	Line Terminal Phase 3

Delta Connected Winding with Tap Changer

Test No	CH1 (Clamp A.1, SIGNAL AND REFERENCE)	CH2 (Clamp A.2, RESPONSE)	Tap Position
1	A,U,R or 1	B,V,S or 2	Max Turns
2	B,V,S or 2	C,W,T or 3	Max Turns
3	C,W,T or 3	A,U,R or 1	Max Turns
4	A,U,R or 1	B,V,S or 2	Tap Winding Out of Circuit
5	B,V,S or 2	C,W,T or 3	Tap Winding Out of Circuit
6	C,W,T or 3	A,U,R or 1	Tap Winding Out of Circuit

Delta Connected Winding without Tap Changer

Test No	CH1 (Clamp A.1, SIGNAL AND REFERENCE)	CH2 (Clamp A.2, RESPONSE)
1	A,U,R or 1	B,V,S or 2
2	B,V,S or 2	C,W,T or 3
3	C,W,T or 3	A,U,R or 1

this page is intentionally left blank

Technical Support

If you are having problems operating the equipment, please do not hesitate to contact our applications engineers on the following email address or via the contact number provided below.

E-mail address: support@newtons4th.com

Repair / Recalibration

In the event of any problem with the instrument, during or outside of the guarantee period, contact your local representative

Newtons4th Ltd offer a full repair and re-calibration service

It is recommended that the instrument be re-calibrated annually

Contact details:

Newtons4th Ltd
30 Loughborough Road
Mountsorrel
Loughborough
LE12 7AT
United Kingdom

Tel: (0116) 230 1066 International: +44 116 230 1066
Fax: (0116) 230 1061 International: +44 116 230 1061

E-mail address: sales@newtons4th.com
office@newtons4th.com

Web site: www.newtons4th.com

We have a policy of continuous product improvement and are always keen to hear comments, whether favourable or unfavourable, from users of our products. Please telephone, fax, write or e-mail with your comments



www.newtons4th.com